

EAGLE PRO II 2452 14ft Crane Body Standard Specifications

Body Materials

- 12 ga A60 galvaneal top and back cabinet panels with 11 ga bottoms utilizing continuous weld construction
- 11 ga A60 galvaneal single panel doors with stainless steel hinges
- 11 ga rigidized A60 galvaneal deck plate and bumper
- rigidized A60 galvaneal cabinet overlay
- 1/4" x 2" x 3" structural tube long sills run full length
- 10 ga 2x4 formed C channel cross rails on 12" centers
- 3/8" workbench top

Body Dimensions

- 99" Overall Body Width
- 24" Overall cabinet depth with 22.5" inside depth clearance
- 52" Overall cabinet height
- 60" vented Oxygen Acetylene cabinet
- 51" x 171" Deck Area
- 31" Deck Side Height
- 7" step Treadplate Bumper
- 25" Workbench with finished full through cabinet

Standard Features

- Body, crane tower, and outriggers rated at 90,000 ft-lbs moment load
- 199 Cubic feet of storage capacity
- Stainless Steel wrap around chip guard full height on front of cabinets
- Full length rain gutter
- Galvanized infinitely adjustable shelving - 250 lb capacity
- 11 Shelf kit
- High Performance cabinet pressurization system with filtered air
- Oxy/Act cabinet is vented, and includes tank brackets for K bottles
- Fully sealed crane tower also functions as a storage cabinet
- 3 point locking door system features blind mounted door handles for security
- Polished stainless steel door handles feature compression latching.
- Outrigger hoses installed internally to eliminate exposure
- (6) Flush mounted cargo tie downs - 3500 lb capacity
- Stainless Steel grab handles
- Stainless Steel spring loaded door checks
- Vise mount on workbench
- Body mounted back-up alarm
- Automotive bulb, steelbacked weather stripping between doors and cabinets
- All wiring is protected in automotive loom
- Logic based electrical system with central fuse and breaker hub
- Body is fully sanded, chemically washed and prepped prior to paint
- 3 step Paint Process with PPG Delfleet Polyurethane topcoat - exterior and interior
- Body is fully undercoated
- LED Lights and reflectors are mounted per DOT specifications
- 2" Class IV receiver hitch rated @ 1,000 lbs tongue weight and 10,000 lbs Gross Trailer Weight
- 7 pole trailer plug
- Standard mounting points for air compressor and welder
- Mud Flaps

Options

- | | | | |
|---------------------------------|----------------------------------|-------------|----------------|
| - Rollout Drawers and Bolt bins | - LED Interior/Exterior Lighting | - Bedliner | - Deck Covers |
| - Gas and Hydraulic Compressors | - All in One Packages | - Lube Kits | - Pintle hitch |

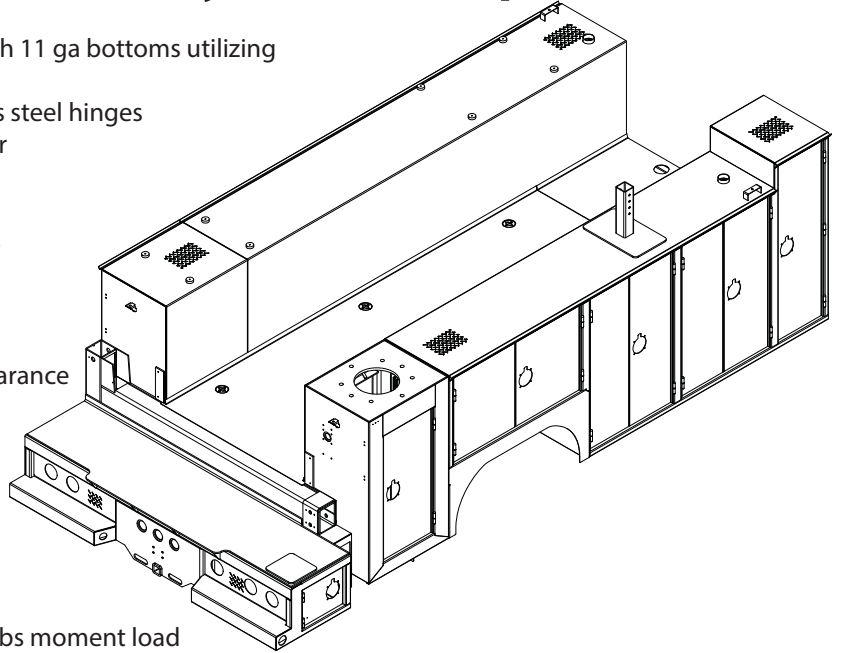

EAGLE PRO II 2452 14ft Crane Body Dimensions

